



COMTUVALVULA

Compañía General de **Tuberías** y Válvulas S.A.S.

**Importador y Distribuidor
Estratégico para sus Proyectos**

Tuberías

Válvulas

Bridas

Accesorios

Espárragos

Sellado de Fluidos

Instrumentación

Otras Líneas

www.comtuvalvula.com
ventas.bogota@comtuvalvula.com
PBX: (57+1) 351 08 00
FAX: (57+1) 360 63 96
Bogotá D.C., Colombia

Bridas

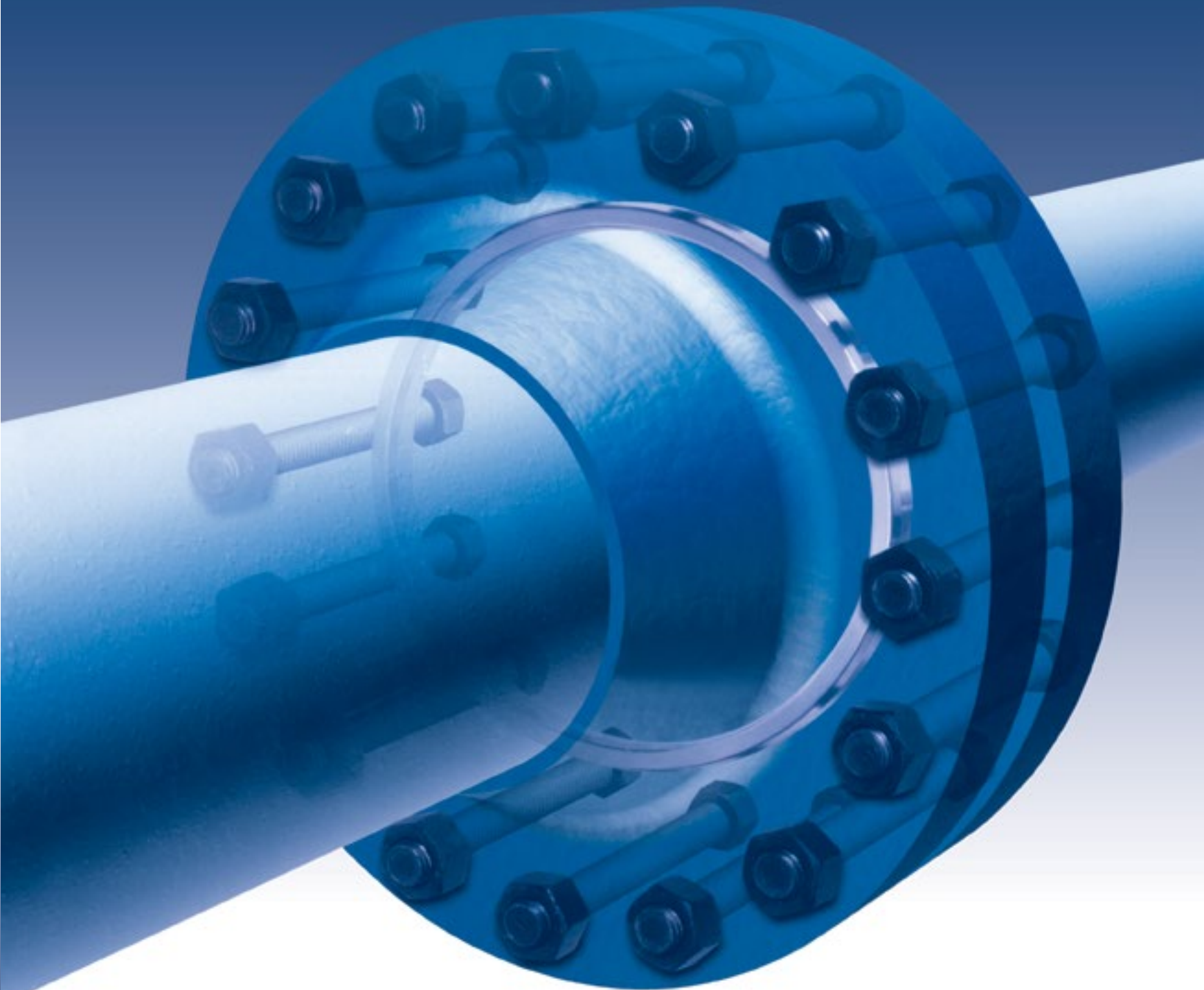

ACERO FORJADO

A-105
A-181
A-350

ACERO CARBÓN ALTA RESISTENCIA

A-694
F42 - F52
F60 - F65
F70 - F80

ACERO INOXIDABLE

304/L
310
316/L
317/L
904/L
347

ESPECIALES

Duplex
Monel
Nickel
Inconel
Hastelloy
Titanium

GRANDES DIÁMETROS ASME B16.47

Series A
Series B

BRIDAS DE ORIFICIO

SPECTACLE
BLIND
FLANGE

BRIDAS ANSI CLASE 150

DIMENSIONES SEGÚN ASME B16.5

DIÁMETRO NOMINAL	O DIÁMETRO EXTERIOR	T ESPESOR	R DIÁMETRO EXTERNO BASE	L2 ALTURA	L ALTURA	B DIÁMETRO INTERIOR Slip On	PESO			NÚMERO DE ORIFICIOS	DIÁMETRO DE ESPÁRRAGO	LONGITUD DE ESPÁRRAGO	F DIÁMETRO DE LLAVE
								CIEGO (Blind)	CON CUELLO (Welding Neck)				
1/2	3,50	0,38	1,38	1,81	0,56	0,88	0,45	0,91	0,91	4	1/2"	2-1/4"	7/8
3/4	3,88	0,44	1,69	2,00	0,56	1,09	0,68	0,91	0,91	4	1/2"	2-1/2"	7/8
1	4,25	0,50	2,00	2,12	0,62	1,36	0,91	0,91	1,14	4	1/2"	2-1/2"	7/8
1 1/4	4,62	0,56	2,50	2,19	0,75	1,70	1,14	1,36	1,14	4	1/2"	2-3/4"	7/8
1 1/2	5,00	0,62	2,88	2,38	0,81	1,95	1,36	1,36	1,81	4	1/2"	2-3/4"	7/8
2	6,00	0,69	3,62	2,44	0,94	2,44	2,18	1,82	2,72	4	5/8"	3-1/4"	1-1/16
2 1/2	7,00	0,81	4,12	2,69	1,06	2,94	3,45	3,18	4,54	4	5/8"	3-1/2"	1-1/16
3	7,50	0,88	5,00	2,69	1,12	3,57	4,01	4,09	5,22	4	5/8"	3-3/4"	1-1/16
3 1/2	8,50	0,88	5,50	2,75	1,19	4,07	4,99	5,90	5,45	8	5/8"	3-3/4"	1-1/16
4	9,00	0,88	6,19	2,94	1,25	4,57	5,63	7,72	7,49	8	5/8"	3-3/4"	1-1/16
5	10,00	0,88	7,31	3,44	1,38	5,66	6,74	9,08	9,53	8	3/4"	3-3/4"	1-1/16
6	11,00	0,94	8,50	3,44	1,50	6,72	7,90	12,26	11,80	8	3/4"	4"	1-1/4
8	13,50	1,06	10,62	3,94	1,69	8,72	12,90	21,34	19,07	8	3/4"	4-1/4"	1-1/4
10	16,00	1,12	12,75	3,94	1,88	10,88	17,60	30,42	24,52	12	7/8"	4-3/4"	1-7/16
12	19,00	1,19	15,00	4,44	2,12	12,88	27,69	45,00	39,95	12	7/8"	4-3/4"	1-7/16
14	21,00	1,31	16,25	4,94	2,19	14,14	37,68	63,11	51,76	12	1"	5-1/4"	1-5/8
16	23,50	1,38	18,50	4,94	2,44	16,16	48,12	84,90	64,47	16	1"	5-1/2"	1-5/8
18	25,00	1,50	21,00	5,44	2,62	18,18	49,49	98,52	74,90	16	1-1/8"	6"	1-13/16
20	27,50	1,62	23,00	5,62	2,81	20,20	67,19	128,48	89,44	20	1-1/8"	6-1/4"	1-13/16
22	29,50	1,75	25,25	5,82	3,07	22,22				20			
24	32,00	1,81	27,25	5,94	3,19	24,25	92,62	188,41	121,67	20	1-1/4"	7"	2

BRIDAS ANSI CLASE 300

DIMENSIONES SEGÚN ASME B16.5

DIÁMETRO NOMINAL	O DIÁMETRO EXTERIOR	T ESPESOR	R DIÁMETRO EXTERNO BASE	L2 ALTURA	L ALTURA	B DIÁMETRO INTERIOR Slip On	PESO			NÚMERO DE ORIFICIOS	DIÁMETRO DE ESPÁRRAGO	LONGITUD DE ESPÁRRAGO	F DIÁMETRO DE LLAVE
							SIN CUELLO (Slip On)	CIEGO (Blind)	CON CUELLO (Welding Neck)				
1/2	3,75	0,50	1,38	2,00	0,81	0,88	0,68	0,91	0,91	4	1/2"	2-1/2"	7/8
3/4	4,62	0,56	1,69	2,19	0,94	1,09	1,14	1,36	1,36	4	5/8"	3"	1-1/16
1	4,88	0,62	2,00	2,38	1,00	1,36	1,36	1,82	1,82	4	5/8"	3"	1-1/16
1 1/4	5,25	0,69	2,50	2,50	1,00	1,70	2,04	2,72	2,27	4	5/8"	3-1/4"	1-1/16
1 1/2	6,12	0,75	2,88	2,63	1,13	1,95	2,95	3,18	3,18	4	3/4"	3-1/2"	1-1/4
2	6,50	0,81	3,62	2,69	1,25	2,44	3,18	3,63	3,63	8	5/8"	3-1/2"	1-1/16
2 1/2	7,50	0,94	4,12	2,94	1,44	2,94	4,54	5,45	5,45	8	5/8"	4"	1-1/16
3	8,25	1,06	5,00	3,06	1,63	3,57	5,90	7,26	8,17	8	3/4"	4-1/4"	1-1/4
3 1/2	9,00	1,12	5,50	3,13	1,69	4,07	7,26	9,53	9,10	8	3/4"	4-1/4"	1-1/4
4	10,00	1,19	6,19	3,32	1,82	4,57	10,67	12,71	12,03	8	3/4"	4-1/2"	1-1/4
5	11,00	1,31	7,31	3,82	1,94	5,66	13,17	16,80	16,34	8	3/4"	4-3/4"	1-1/4
6	12,50	1,38	8,50	3,82	2,00	6,72	16,34	21,79	20,43	12	3/4"	5"	1-1/4
8	15,00	1,56	10,62	4,32	2,38	8,72	25,42	35,87	31,33	12	7/8"	5-1/2"	1-7/16
10	17,50	1,81	12,75	4,56	2,56	10,88	34,96	55,39	45,40	16	1"	6-1/4"	1-5/8
12	20,50	1,94	15,00	5,06	2,82	12,88	51,30	83,08	64,47	16	1-1/8"	6-3/4"	1-13/16
14	23,00	2,06	16,25	5,56	2,94	14,14	72,19	109,41	93,52	20	1-1/8"	7"	1-13/16
16	25,50	2,19	18,50	5,69	3,19	16,16	95,34	143,01	113,05	20	1-1/4"	7-1/2"	2
18	28,00	2,31	21,00	6,19	3,44	18,18	114,86	187,96	138,92	24	1-1/4"	7-3/4"	2
20	30,50	2,44	23,00	6,32	3,69	20,20	139,38	233,81	167,53	24	1-1/4"	8-1/4"	2
22	33,00	2,57	25,25	6,43	3,93	22,22				24			
24	36,00	2,69	27,25	6,56	4,13	24,25	222,46	363,20	235,63	24	1-1/2"	9-1/4"	2-3/8

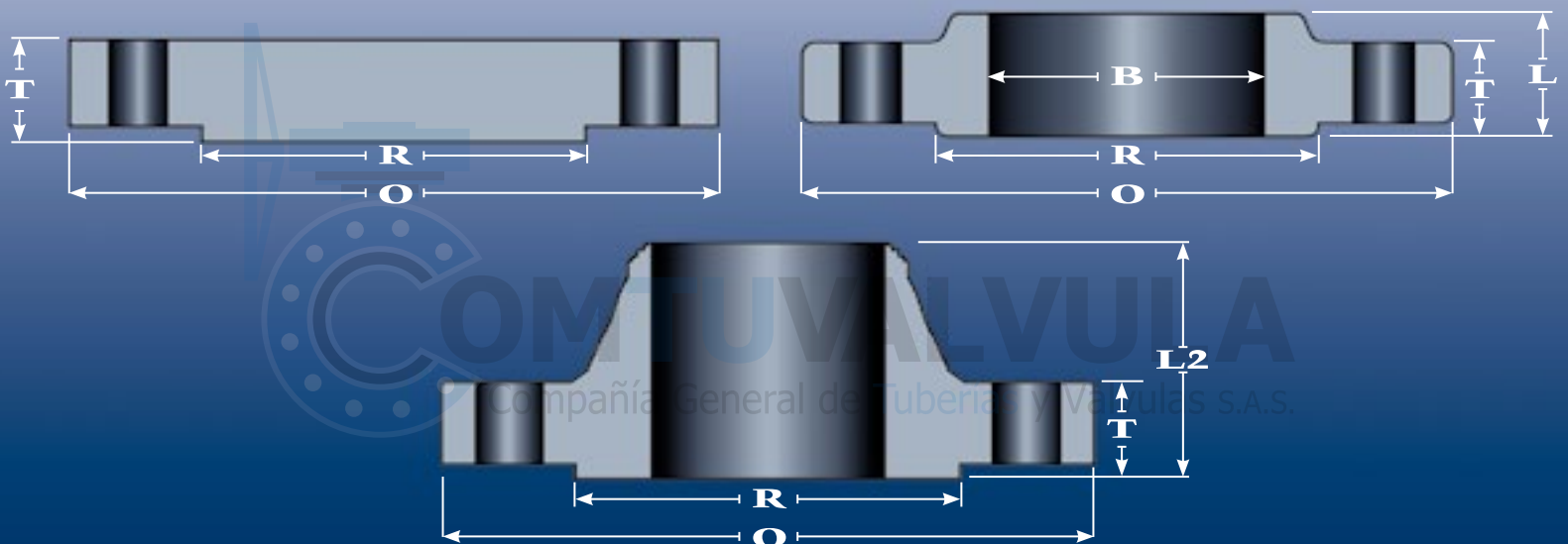

BRIDAS ANSI CLASE 600

DIMENSIONES SEGÚN ASME B16.5

DIAMETRO NOMINAL	O DIAMETRO EXTERIOR	T ESPESOR	R DIAMETRO EXTERNO BASE	L2 ALTURA	L ALTURA	B DIAMETRO INTERIOR Slip On	PESO			NÚMERO DE ORIFICIOS	DIAMETRO DE ESPÁRRAGO	LONGITUD DE ESPÁRRAGO	F DIAMETRO DE LLAVE
							SIN CUELLO (Slip On)	CIEGO (Blind)	CON CUELLO (Welding Neck)				
1/2	3,75	0,56	1,38	2,06	0,88	0,88	0,91	0,91	1,36	4	1/2"	3"	7/8
3/4	4,62	0,62	1,69	2,25	1,00	1,09	1,36	1,36	1,59	4	5/8"	3-1/2"	1-1/16
1	4,88	0,69	2,00	2,44	1,06	1,36	1,59	1,82	1,82	4	5/8"	3-1/2"	1-1/16
1 1/4	5,25	0,81	2,50	2,62	1,12	1,70	2,04	2,72	2,50	4	5/8"	3-3/4"	1-1/16
1 1/2	6,12	0,88	2,88	2,75	1,25	1,95	2,95	3,63	3,63	4	3/4"	4-1/4"	1-1/4
2	6,50	1,00	3,62	2,88	1,44	2,44	3,63	4,54	4,54	8	5/8"	4-1/2"	1-1/16
2 1/2	7,50	1,12	4,12	3,12	1,62	2,94	5,45	6,81	6,36	8	3/4"	4-3/4"	1-1/4
3	8,25	1,25	5,00	3,25	1,81	3,57	6,81	9,08	8,17	8	3/4"	5"	1-1/4
3 1/2	9,00	1,38	5,50	3,38	1,94	4,07	9,53	13,17	11,80	8	7/8"	5-1/2"	1-7/16
4	10,75	1,50	6,19	4,00	2,12	4,57	14,98	18,61	16,80	8	7/8"	5-3/4"	1-7/16
5	13,00	1,75	7,31	4,50	2,38	5,66	28,60	30,87	30,87	8	1"	6-1/2"	1-5/8
6	14,00	1,88	8,50	4,62	2,62	6,72	36,32	39,04	33,14	12	1"	6-3/4"	1-5/8
8	16,50	2,19	10,62	5,25	3,00	8,72	44,04	63,11	50,85	12	1-1/8"	7-3/4"	1-13/16
10	20,00	2,50	12,75	6,00	3,38	10,88	80,36	104,87	85,81	16	1-1/4"	8-1/2"	2
12	22,00	2,62	15,00	6,12	3,62	12,88	97,61	133,93	102,60	20	1-1/4"	8-3/4"	2
14	23,75	2,75	16,25	6,50	3,69	14,14	117,59	148,91	157,54	20	1-3/8"	9-1/4"	2-3/16
16	27,00	3,00	18,50	7,00	4,19	16,16	166,16	239,26	218,37	20	1-1/2"	10"	2-3/8
18	29,25	3,25	21,00	7,25	4,62	18,18	216,10	301,91	251,97	20	1-5/8"	10-3/4"	2-9/16
20	32,00	3,50	23,00	7,50	5,00	20,20	277,85	388,17	313,26	24	1-5/8"	11-1/2"	2-9/16
22	34,25	3,75	25,25	7,75	5,25	22,22				24			
24	37,00	4,00	27,25	8,00	5,50	24,25	397,70	533,45	443,56	24	1-7/8"	13-1/4"	2-15/16

BRIDAS ANSI CLASE 900

DIMENSIONES SEGÚN ASME B16.5

DIAMETRO NOMINAL	O DIAMETRO EXTERIOR	T ESPESOR	R DIAMETRO EXTERNO BASE	L2 ALTURA	L ALTURA	B DIAMETRO INTERIOR Slip On	PESO			NÚMERO DE ORIFICIOS	DIAMETRO DE ESPÁRRAGO	LONGITUD DE ESPÁRRAGO	F DIAMETRO DE LLAVE
							SIN CUELLO (Slip On)	CIEGO (Blind)	CON CUELLO (Welding Neck)				
3	9,50	1,50	5,00	4,00	2,13	3,57	14,07	14,53	13,17	8	7/8"	5-3/4"	1-7/16
4	11,50	1,75	6,19	4,50	2,75	4,57	24,06	24,52	23,15	8	1-1/8"	6-3/4"	1-13/16
5	13,75	2,00	7,31	5,00	3,13	5,66	37,68	39,50	39,04	8	1-1/4"	7-1/2"	2
6	15,00	2,19	8,50	5,50	3,38	6,72	49,03	51,30	49,94	12	1-1/8"	7-3/4"	1-13/16
8	18,50	2,50	10,63	6,38	4,00	8,72	78,09	89,44	84,90	12	1-3/8"	8-3/4"	2-3/16
10	21,50	2,75	12,75	7,25	4,25	10,88	111,23	131,66	121,67	16	1-3/8"	9-1/4"	2-3/16
12	24,00	3,13	15,00	7,88	4,63	12,88	148,00	187,50	168,89	20	1-3/8"	10"	2-3/16
14	25,25	3,38	16,25	8,38	5,13	14,14	172,52	224,28	255,15	20	1-1/2"	11"	2-3/8
16	27,75	3,50	18,50	8,50	5,25	16,16	208,39	281,03	310,99	20	1-5/8"	11-1/2"	2-9/16
18	31,00	4,00	21,00	9,00	6,00	18,18	293,74	399,52	419,50	20	1-7/8"	13-1/4"	2-15/16
20	33,75	4,25	23,00	9,75	6,25	20,20	359,57	502,58	528,46	20	2"	14-1/4"	3-1/8
24	41,00	5,50	27,25	11,50	8,00	24,25	671,92	952,95	956,58	20	2-1/2"	18"	3-7/8

Dimensiones O - T - R - L2 - L - B en Pulgadas.
 Peso calculado en Kilogramos.
 Diámetro interior de Welding Neck ver Tablas de Tuberías
 Tolerancias ver Norma ASME B16.5

Diámetros de 1/2" a 2 1/2" son idénticas a ANSI Clase 1.500

Blind



Slip On



Welding Neck



BRIDAS ANSI CLASE 1500

DIMENSIONES SEGÚN ASME B16.5

DIÁMETRO NOMINAL	O DIÁMETRO EXTERIOR	T ESPESOR	R DIÁMETRO EXTERNO BASE	L2 ALTURA	L ALTURA	B DIÁMETRO INTERIOR Slip On	PESO			NÚMERO DE ORIFICIOS	DIÁMETRO DE ESPÁRRAGO	LONGITUD DE ESPÁRRAGO	F DIÁMETRO DE LLAVE
							SIN CUELLO (Slip On)	CIEGO (Blind)	CON CUELLO (Welding Neck)				
1/2	4,75	0,88	1,38	2,38	1,25	0,88	2,72	1,82	3,18	4	3/4"	4-1/4"	1-1/4
3/4	5,13	1,00	1,69	2,75	1,38	1,09	2,72	2,72	3,18	4	3/4"	4-1/2"	1-1/4
1	5,88	1,13	2,00	2,88	1,63	1,36	3,41	4,09	3,86	4	7/8"	5"	1-7/16
1 1/4	6,25	1,13	2,50	2,88	1,63	1,70	4,54	4,54	4,54	4	7/8"	5"	1-7/16
1 1/2	7,00	1,25	2,88	3,25	1,75	1,95	6,36	6,36	6,36	4	1"	5-1/2"	1-5/8
2	8,50	1,50	3,63	4,00	2,25	2,44	9,99	11,35	10,90	8	7/8"	5-3/4"	1-7/16
2 1/2	9,63	1,63	4,13	4,13	2,50	2,94	16,34	15,89	16,34	8	1"	6-1/4"	1-5/8
3	10,50	1,88	5,00	4,63	2,88	3,57	21,79	21,79	21,79	8	1-1/8"	7"	1-13/16
4	12,25	2,13	6,19	4,88	3,56	4,57	33,14	33,14	31,33	8	1-1/4"	7-3/4"	2
5	14,75	2,88	7,31	6,13	4,13	5,66	59,93	64,47	59,93	8	1-1/2"	9-3/4"	2-3/8
6	15,50	3,25	8,50	6,75	4,69	6,72	74,46	72,19	74,46	12	1-3/8"	10-1/2"	2-3/16
8	19,00	3,63	10,63	8,38	5,63	8,72	117,13	137,11	123,94	12	1-5/8"	12-3/4"	2-9/16
10	23,00	4,25	12,75	10,00	6,25	10,88	197,94	230,18	206,12	12	1-7/8"	13-1/2"	2-15/16
12	26,50	4,88	15,00	11,13	7,13	12,88	302,82	351,85	313,26	16	2"	15-1/4"	3-1/8
14	29,50	5,25	16,25	11,75				442,3	426,38	16	2-1/4"	16-3/4"	3-1/2
16	32,50	5,75	18,50	12,25				589,7	566,99	16	2-1/2"	18-1/2"	3-7/8
18	36,00	6,38	21,00	12,88				793,8	737,09	16	2-3/4"	20-3/4"	4-1/4
20	38,75	7,00	23,00	14,00				1.009,2	929,9	16	3"	22-1/4"	4-5/8
24	46,00	8,00	27,25	16,00				1.644,3	1.508,2	16	3-1/2"	25-1/2"	5-3/8

BRIDAS ANSI CLASE 2500

DIMENSIONES SEGÚN ASME B16.5

DIÁMETRO NOMINAL	O DIÁMETRO EXTERIOR	T ESPESOR	R DIÁMETRO EXTERNO BASE	L2 ALTURA	L ALTURA	B DIÁMETRO INTERIOR Slip On	PESO			NÚMERO DE ORIFICIOS	DIÁMETRO DE ESPÁRRAGO	LONGITUD DE ESPÁRRAGO	F DIÁMETRO DE LLAVE
							SIN CUELLO (Slip On)	CIEGO (Blind)	CON CUELLO (Welding Neck)				
1/2	5,25	1,19	1,38	2,88	1,56	0,88	3,18	3,18	3,63	4	3/4"	4-3/4"	1-1/4
3/4	5,50	1,25	1,69	3,13	1,69	1,09	4,09	4,54	4,09	4	3/4"	5"	1-1/4
1	6,25	1,38	2,00	3,50	1,88	1,36	5,45	5,45	5,90	4	7/8"	5-1/2"	1-7/16
1 1/4	7,25	1,50	2,50	3,75	2,06	1,70	8,17	8,17	9,08	4	1"	6"	1-5/8
1 1/2	8,00	1,75	2,88	4,38	2,38	1,95	11,35	11,35	12,71	4	1-1/8"	6-3/4"	1-13/16
2	9,25	2,00	3,63	5,00	2,75	2,44	17,25	17,71	19,07	8	1"	7"	1-5/8
2 1/2	10,50	2,25	4,13	5,63	3,13	2,94	24,97	25,42	23,61	8	1-1/8"	8"	1-13/16
3	12,00	2,63	5,00	6,63	3,63	3,57	37,68	39,04	42,68	8	1-1/4"	9"	2
4	14,00	3,00	6,19	7,50	4,25	4,57	57,66	60,38	66,28	8	1-1/2"	10-1/4"	2-3/8
5	16,50	3,63	7,31	9,00	5,13	5,66	95,34	101,24	110,78	8	1-3/4"	12-1/4"	2-3/4
6	19,00	4,25	8,50	10,75	6,00	6,72	146,64	156,63	171,61	8	2"	14"	3-1/8
8	21,75	5,00	10,63	12,50	7,00	8,72	220,19	241,98	261,50	12	2"	15-1/2"	3-1/8
10	26,50	6,50	12,75	16,50	9,00	10,88	419,95	465,35	484,87	12	2-1/2"	20"	3-7/8
12	30,00	7,25	15,00	18,25	10,00	12,88	590,20	644,66	730,03	12	2-3/4"	22"	4-1/4

Dimensiones **O - T - R - L2 - L - B** en Pulgadas.
 Peso calculado en Kilogramos.
 Diámetro interior de Welding Neck ver Tablas de Tuberías
 Tolerancias ver Norma ASME B16.5

