



COMTUVALVULA

Compañía General de **Tuberías** y Válvulas S.A.S.

**Importador y Distribuidor
Estratégico para sus Proyectos**

Tuberías

Válvulas

Bridas

Accesorios

Espárragos

Sellado de Fluidos

Instrumentación

Otras Líneas

www.comtuvalvula.com
ventas.bogota@comtuvalvula.com
PBX: (57+1) 351 08 00
FAX: (57+1) 360 63 96
Bogotá D.C., Colombia

Válvulas



VÁLVULAS TIPO COMPUERTA

ACERO CARBÓN - INOXIDABLE Y ALEACIONES. CONSTRUCCIÓN SEGÚN API 600 & API 603. ASME B16.34

CLASE DIÁMETRO NOMINAL	150		300		600			900			1500			2500		
	L R.F.	PESO (Kg)	L R.F.	PESO (Kg)	L		PESO (Kg)	L		PESO (Kg)	L		PESO (Kg)	L		PESO (Kg)
					R.F.	R.T.J.		R.F.	R.T.J.		R.F.	R.T.J.		R.F.	R.T.J.	
2"	7,0	19	8,5	24	11,5	11,62	33	14,5	14,62	70	14,5	14,62	70	17,75	17,88	135
2-1/2"	7,5	25	9,5	35	13,0	13,12	47	16,5	16,62	95	16,5	16,62	110	20,00	20,25	210
3"	8,0	31	11,1	48	14,0	14,12	69	15,0	15,12	120	18,5	18,62	170	22,75	23,00	256
4"	9,0	46	12,0	70	17,0	17,12	122	18,0	18,12	148	21,5	21,62	245	26,50	26,88	498
5"	10,0	62	15,0	101	20,0											
6"	10,5	78	15,9	139	22,0	22,12	260	24,0	24,12	415	27,8	28,00	650	36,00	36,50	1.550
8"	11,5	130	16,5	207	26,0	26,12	420	29,0	29,12	650	32,8	33,13	995	40,25	40,88	2.395
10"	13,0	185	18,0	311	31,0	31,12	640	33,0	32,12	1.085	39,0	39,38	1.850	50,00	50,88	4.460
12"	14,0	285	19,8	427	33,0	33,12	855	38,0	38,12	1.530	44,5	45,12	2.650	56,00	56,88	6.320
14"	15,0	385	30,0	615	35,0	35,12	1.210	40,5	40,88	2.190	49,5	50,25	4.050	62,00		8.310
16"	16,0	540	33,0	915	39,0	39,12	1.485	44,5	44,88	2.880	54,5	55,38	5.960	68,00		9.870
18"	17,0	685	36,0	1.160	43,0	43,12	1.875	48,0	48,50	3.370	60,5	61,40	6.890	74,00		11.850
20"	18,0	855	39,0	1.595	47,0	47,25	2.670	52,0	52,48	4.350	65,5	66,40	8.200	80,00		14.210
24"	20,0	1.185	45,0	2.270	55,0	55,38	3.830	61,0	61,73	5.930	76,5	77,60	9.750	92,00		16.300
26"	22,0	1.420	49,0	2.895	57,0	57,50	4.610	65,0		7.100	82,0		15.550			
28"	24,0	1.850	53,0	3.370	61,0	61,50	5.600	70,0		8.445	87,5		16.950			
30"	24,0	2.380	55,0	3.786	65,0	65,50	6.350	74,0		9.680	93,0		19.250			
32"	26,0	2.850	60,0	4.580	70,0	70,60	7.850									
36"	28,0	3.420	68,0	5.900	82,0	82,60	9.970	87,0		12.840						
40"	30,0	4.650	76,0	8.100	90,0	90,60	13.610									
42"	31,0	5.075	78,0	9.750	96,0	96,60	16.380									
48"	34,0	7.250	88,0	13.050	100,0	100,60	21.925									

VÁLVULAS TIPO GLOBO

ACERO CARBÓN - INOXIDABLE Y ALEACIONES. CONSTRUCCIÓN SEGÚN BS1873. ASME B16.34

CLASE DIÁMETRO NOMINAL	150		300		600			900			1500			2500		
	L R.F.	PESO (Kg)	L R.F.	PESO (Kg)	L		PESO (Kg)	L		PESO (Kg)	L		PESO (Kg)	L		PESO (Kg)
					R.F.	R.T.J.		R.F.	R.T.J.		R.F.	R.T.J.		R.F.	R.T.J.	
2"	8,0	21	10,50	27	11,5	11,62	38	14,5	14,62	90	14,5	14,62	95	17,8	17,88	170
2-1/2"	8,5	27	11,50	38	13,0	13,12	51	16,5	16,62	118	16,5	16,62	145	20,0	20,25	255
3"	9,5	36	12,50	52	14,0	14,12	72	15,0	15,12	131	18,5	18,62	230	22,8	23,00	315
4"	11,5	52	14,00	74	17,0	17,12	142	18,0	18,12	218	21,5	21,62	330	26,5	26,88	740
5"	14,0	71	15,75	115												
6"	16,0	92	17,50	148	22,0	22,12	295	24,0	24,12	482	27,8	28,00	780	36,0	36,50	1.850
8"	19,5	152	22,00	260	26,0	26,12	505	29,0	29,12	725	32,8	33,13	1.100	40,3	40,88	3.740
10"	24,5	248	24,50	440	31,0	31,12	920	33,0	33,10	1.100	39,0	39,40	2.100	50,0	50,90	4.990
12"	27,5	476	28,00	728	33,0	33,12	1.290	38,0	38,10	1.450	44,5	45,10	2.930			
14"	31,0	620	33,00	1.100	35,0	35,12	1.550	40,5	40,90	2.320						
16"	36,0	880	34,00	1.550	39,0	39,12	1.960	44,5	44,90	3.210						
18"	38,5	1.350	38,50	2.320	43,0	43,12	3.050									
20"	38,5	1.850	40,00	3.100												
24"	51,0	2.950														

VÁLVULAS DE RETENCIÓN COMPUERTA

ACERO CARBÓN - INOXIDABLE Y ALEACIONES. CONSTRUCCIÓN SEGÚN BS1868. ASME B16.34

CLASE DIÁMETRO NOMINAL	150		300		600			900			1500			2500		
	L R.F.	PESO (Kg)	L R.F.	PESO (Kg)	L		PESO (Kg)	L		PESO (Kg)	L		PESO (Kg)	L		PESO (Kg)
					R.F.	R.T.J.		R.F.	R.T.J.		R.F.	R.T.J.		R.F.	R.T.J.	
2"	8,0	14	10,50	20	11,5	11,62	29	14,5	14,62	65	14,50	14,62	65	17,75	17,87	130
2-1/2"	8,5	19	11,50	28	13,0	13,12	41	16,5	16,62	85	16,50	16,62	85	20,00	20,25	200
3"	9,5	24	12,50	35	14,0	14,12	52	15,0	15,12	105	18,50	18,62	129	22,75	23,00	240
4"	11,5	40	14,00	60	17,0	17,12	98	18,0	18,12	139	21,50	21,62	232	26,50	26,88	450
5"	13,0	55	15,75	80	20,0	20,12	159									
6"	14,0	71	17,50	115	22,0	22,12	219	24,0	24,12	350	27,75	28,00	490	36,00	36,50	1.220
8"	19,5	120	21,00	180	26,0	26,12	365	29,0	29,12	580	32,75	33,13	930	40,25	40,87	2.230
10"	24,5	170	24,50	290	31,0	31,12	545	33,0	33,12	810	39,00	39,38	1.485	50,00	50,88	3.690
12"	27,5	255	28,00	410	33,0	33,12	760	38,0	38,12	1.250	44,50	45,12	2.100	56,00	56,88	5.480
14"	31,0	320	33,00	575	35,0	35,12	913	40,5	40,88	1.680	49,50	50,25	3.180	62,00		7.430
16"	34,0	510	34,00	810	39,0	39,12	1.290	44,5	44,88	2.320	54,50	55,38	4.380	68,00		8.990
18"	38,5	621	38,50	925	43,0	43,12	1.490	48,0	48,50	2.950	60,50	61,40	5.950	73,90		10.920
20"	38,5	822	40,00	1.250	47,0	47,25	1.980	52,0	52,50	3.820	65,50	66,40	7.680	79,90		12.670
24"	51,0	985	53,00	1.780	55,0	55,38	3.100	61,0	61,70	5.120	76,50	77,60	8.950	91,90		14.450
26"	51,0	1.350	53,00	2.350	57,0	57,50	3.720	65,0	65,90	6.430	82,00		11.975			
28"	57,0	1.720	59,00	2.620	63,0	63,50	4.550	69,0	69,90	7.620	87,50		13.100			
30"	60,0	2.120	62,75	3.475	65,0	65,50	5.410	73,0	73,90	8.780	93,00		14.950			
32"	68,0	2.621	68,00	3.790	70,0	70,60	6.480									
36"	77,0	3.050	82,00	4.725	82,0	82,60	8.270									

L Entre bridas R.F.
L Entre bridas R.T.J.
Peso en Kilogramos

Dimensión entre extremos "L" en pulgadas según ASME B16.10.
Peso calculado aproximado. Difiere entre fabricantes

DENOMINACIÓN DE MATERIALES SEGÚN PROCESO DE FABRICACIÓN

DESIGNACIÓN EN FORJA	DESIGNACIÓN EN ALEACIÓN (ALLOY)	EQUIVALENTE EN FUNDICIÓN
304	ASTM A-744	CF 8
304 L	ASTM A-744	CF 3
304 H	ASTM A-352	CF 10
304 Modified	ASTM A-744	CF 8. 4Min/0,8 Max
316	ASTM A-351/A-744	CF8M
316 L	ASTM A-744	CF3M
317	ASTM A-744	CG8M
317 L	ASTM A-744	CG3M
317 LM	ASTM A-744	CG3M Modificado
347	ASTM A-744	CF8C
347 H	ASTM A-351	CF8C Modificado
405	ASTM A -352	CA6NM
410	ASTM A -487	CA15-C
Alloy 20	ASTM A-744	CN7M
Monel 400	ASTM A-494	M35-1
Monel	ASTM A-494	M35-2
Monel	ASTM A-479	M-30H
Duplex SS-Bar	ASTM A-479	Ferrallium 255
Duplex SS-Bar	ASTM A-479	S-31803
Duplex -Cast	ASTM A-744	CD-4MCU
Duplex SS-Cast 2205	ASTM A-890	CD-3MN
Nickel 200	ASTM A-494	CZ100
Inconel 600	ASTM A-494	CY40-CL1
Inconel 600	ASTM A-494	CY40-CL2
Inconel 625	ASTM A-494	CW6MC
Incoenl 800	ASTM A-351	CTI5C
Inconel 800 H	ASTM A-351	CTI5C
Hastelloy	ASTM A-494	N7MCL1
Hast. B-Cast	ASTM A-494	N-12MV
Hast. B-2 Bar	ASME SB-335	N10665
Hast. C-Cast	ASTM A-494	CW12MW
Hast. C-276 Bar	ASME SB-574	N10276
Hast. C4	ASTM A-494	CW2M
Hast. C4 Cast Modified	ASTM A- 474	CW2M Clase 1 Modificado
Hast. C-22 Bar	ASME SB 574	NO 6022
Hast. C-22 Cast	ASTM A -494	CX2MW
Titanium	ASTM B-367	GR2
Titanium	ASTM B-367	GR3
Titanium	ASTM B-367	GRC5
Titanium	ASTM B-367	GR7B
Avesta 254 SMO	ASTM A-351/NO 8926	CK3MCUN
Zirconium-Cast	ASTM B-752	GR 702 C

TRIM O GUARNICIÓN INTERIOR SEGÚN API 600

API TRIM No.	TRIM NOMINAL	DENOMINACIÓN DE MATERIAL	ASIENTO	DISCO	ASIENTO TRASERO	VÁSTAGO	NOTA
1	F6	410	410	410	410	410	
2	304	304	304	304	304	304	
3	310	F310	310	310	310	310	
4	Hard F6	Hard 410	Hard 410	Hard 410	410	410	Asientos 750 BHN Min
5	HardFaced	Hardfaced	Stellite	Stellite	410	410	
5A	HardFaced	Hardfaced	Ni-Cr	Ni-Cr	410	410	
6	F6 & Cu-Ni	410 & Cu-Ni	Cu-Ni	410	410	410	
7	F6 & Hard F6	410 & Hard 410	Hard 410	Hard 410	410	410	Asientos 750 BHN Min
8	F6 & HardFaced	410 & Hardfaced	Stellite	410	410	410	
8A	F6 & HardFaced	410 & Hardfaced	Ni-Cr	410	410	410	
9	Monel	Monel	Monel	Monel	Monel	Monel	
10	316	316	316	316	316	316	
11	Monel & HardFaced	Monel & Hardface	Stellite	Monel	Monel	Monel	
12	316 & HardFaced	316 & Hardfaced	Stellite	316	316	316	
13	Alloy 20	Alloy 20	Alloy 20	Alloy 20	Alloy 20	Alloy 20	
14	Alloy 20 & HardFaced	Alloy 20 and HardFaced	Stellite	Alloy 20	Alloy 20	Alloy 20	
15	HardWare	304 & Hardfaced	Stellite	Stellite	304	304	
16	HardFaced	316 & Hardfaced	Stellite	Stellite	316	316	
17	HardWare	347 & Hardfaced	Stellite	Stellite	347	347	
18	HardFaced	Alloy 20 & Hardfaced	Stellite	Stellite	Alloy 20	Alloy 20	

EQUIVALENCIA DE MATERIALES

FUNDICIÓN	TUBERÍA	FORJA	LAMINADO	BARRA
A216 WCB	A106 GR.B	A105	A516 GR.70	A105
A217 WC1	A335 P1	A182 F1	A204 GR. A	-
A217 WC6	A335 P11	A182 F11	A387 GR.11	A739 B11
A217 WC9	A335 P22	A182 F.22	A387 GR. 22	A739 B22
A217 C5	A335 P5	A182 F5	A387 GR.5	A182 F5
A217 C12	A395 P9	A182 F9	A387 GR.9	A182 F9
A217 CA15	-	A182 F6	A240 TP 410	A479 TP 410
A352 LCB	A333 GR.6	A350 LF2	A516 GR.70	A696 GR.C
A352 LC2	A333 GR.7	-	A203 GR.B	-
A352 LC3	A333 GR.3	A350 LF3	A203 GR.E	-
A352 LC3	A333 GR.3	A350 LF3	A203 GR.E	-
A351 CF3	A312 TP 304L	A182 F 304L	A240 TP 304L	A479 TP 304L
A351 CF3M	A312 TP 316L	A182 F 316L	A240 TP 316L	A479 TP 316L
A351 CF8	A312 TP 304	A182 F 304	A240 TP 304	A479 TP 304
A351 CF8C	A312 TP 347	A182 F 347	A240 TP 347	A479 TP 347
A351 CF8M	A312 TP 316	A182 F 316	A240 TP 316	A479 TP 316

Compuerta

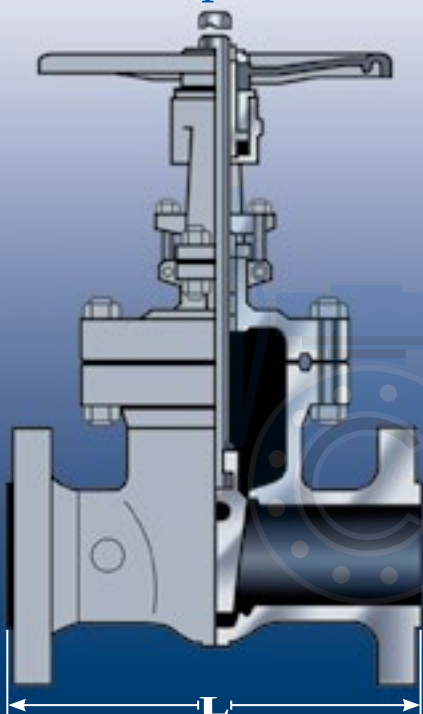

Globo

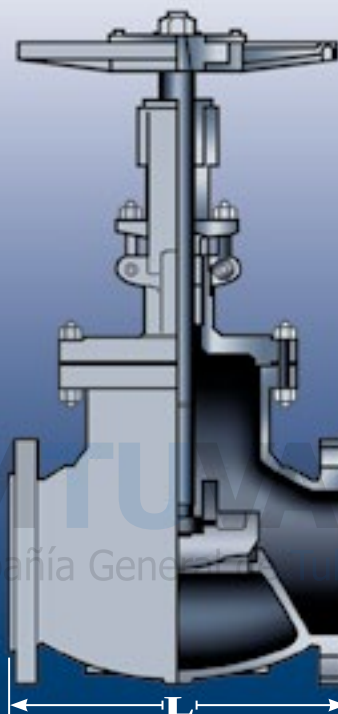

Cheque



Copyright © 2010 COMTUVALVULA S.A.S. Todos los Derechos Reservados.
Prohibida su Reproducción Total y/o Parcial en cualquier forma o medio
sin el permiso o licencia por escrito de COMTUVALVULA S.A.S.

VÁLVULAS BOLA TIPO FLOTANTE

ACERO CARBÓN - INOXIDABLE Y ALEACIONES.
CONSTRUCCIÓN SEGÚN API 608.

CLASE	150		300		600	
	L R.F.	PESO (Kg)	L R.F.	PESO (Kg)	L R.F.	PESO (Kg)
2"	7,00	11,0	8,50	15,0	11,50	20,0
2-1/2"	7,52	15,0	9,49	26,0		
3"	8,00	20,0	11,12	33,0	14,00	43,0
4"	9,00	31,0	12,00	54,0	17,00	85,0
5"	14,02	51,0	15,00	85,0		
6"	15,50	78,0	15,88	118,0		
8"	18,00	120,0	19,75	220,0		
10"	21,00	195,0	22,38	410,0		
12"	24,00	310,0	25,50	540,0		

VÁLVULAS BOLA TIPO TRUNNION

DE 3 PIEZAS EN ACERO CARBÓN - INOXIDABLE Y ALEACIONES. CONSTRUCCIÓN SEGÚN API 6D.

CLASE	150		300		600			900			1500			2500		
	L R.F.	PESO (Kg)	L R.F.	PESO (Kg)	L R.F.	L R.T.J.	PESO (Kg)	L R.F.	L R.T.J.	PESO (Kg)	L R.F.	L R.T.J.	PESO (Kg)	L R.F.	L R.T.J.	PESO (Kg)
2"	7,0	22	8,5	28	11,5	11,625	34	14,5	14,625	59	14,50	14,625	59	17,75	17,875	95
3"	8,0	34	11,13	47	14,0	14,125	66	15,0	15,125	85	18,50	18,625	115	22,75	23,000	210
4"	9,0	52	12,0	75	17,0	17,125	120	18,0	18,125	165	21,50	21,625	210	26,50	26,875	375
6"	15,5	160	15,88	205	22,0	22,125	275	24,0	24,125	385	27,75	28,000	490	36,00	36,500	835
8"	18,0	335	19,75	385	26,0	26,125	492	29,0	29,125	625	32,75	33,125	780	40,25	40,875	1.430
10"	21,0	425	22,38	530	31,0	31,125	745	33,0	33,125	950	39,00	39,125	1.560	50,00	50,875	2.520
12"	24,0	585	25,5	780	33,0	33,125	1.060	38,0	38,125	1.280	44,50	45,125	1.980	56,00	56,875	3.460
14"	27,0	805	30,0	1.025	35,0	35,125	1.250	40,5	40,875	1.625	49,50	50,250	2.780			
16"	30,0	1.070	33,0	1.415	39,0	39,125	1.680	44,5	44,875	1.995	54,50	55,375	3.890			
18"	34,0	1.370	36,0	1.685	43,0	43,125	2.180	48,0	48,500	2.920	60,50	61,375	5.380			
20"	36,0	1.830	39,0	2.140	47,0	47,250	2.780	52,0	52,500	3.560	65,50	66,375	6.240			
24"	42,0	2.980	45,0	3.420	55,0	55,375	4.835	61,0	61,750	5.560	80,50	81,500	7.380			
26"	45,0	3.650	49,0	4.340	57,0	57,500	5.830	65,0	66,000	7.620						
28"	49,0	4.380	53,0	4.990	61,0	61,500	6.380	69,0	69,875	8.450						
30"	51,0	5.280	55,0	5.890	65,0	65,500	7.450	74,0	74,875	10.850						
32"	54,0	6.225	60,0	7.525	70,0	70,625	8.325	80,0	80,875	11.830						
36"	60,0	8.720	68,0	9.460	82,0	82,625	11.460	90,0	91,125	16.250						
40"	69,0	11.730	77,0	12.710	92,0	92,000	15.550									
42"	73,0	12.970	82,0	14.110	96,0	96,000	18.175									
48"	84,0	18.170	85,44	19.890	100,0	100,000	25.350									

L Entre bridas R.F.
L Entre bridas R.T.J.
Peso en Kilogramos

Dimensión entre extremos "L" en pulgadas según ASME B16.10.
Diseño largo (Long Pattern)
Peso calculado aproximado. Difiere entre fabricantes
No incluye operador de engranaje.

Flotante

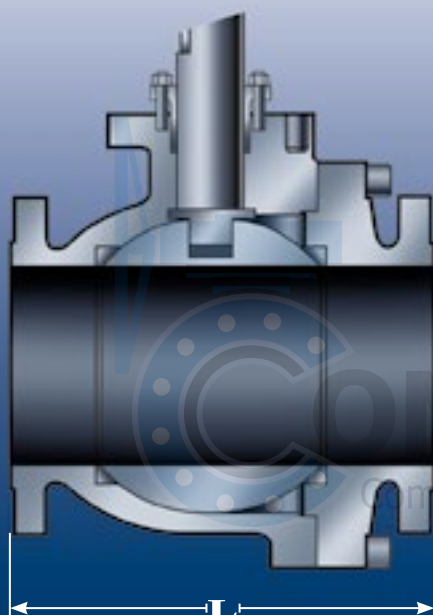

Trunnion

